

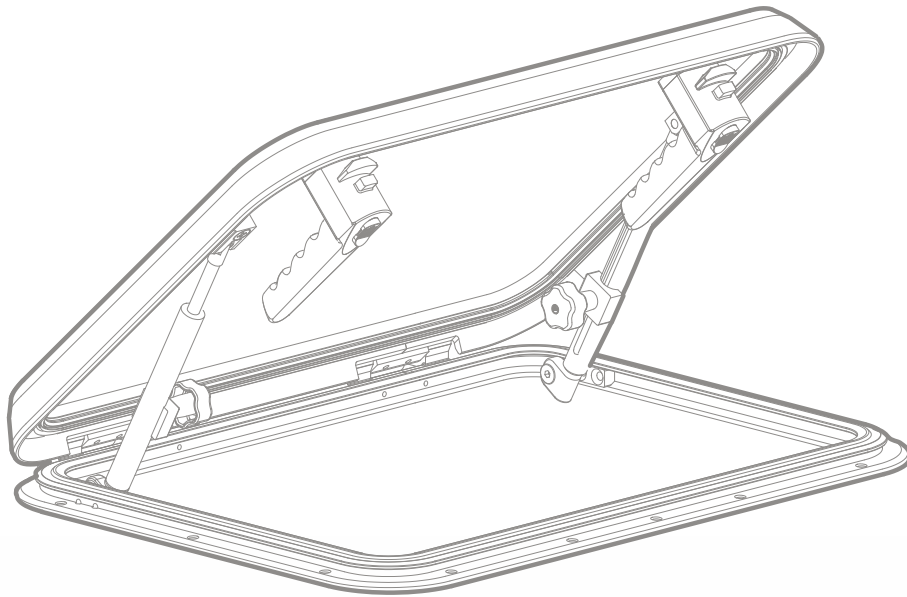

Craftsman
MARINE



SIRIUS DECK HATCH

MANUAL

CRAFTED WITH CRAFTSMAN MARINE

DECK EQUIPMENT

Thank you very much for purchasing a Craftsman Marine escape or ventilation hatch.

You have made an excellent choice and our Craftsman Marine Service Team will gladly be of the best possible assistance, if and when you will need us.

The hatches made by Craftsman Marine are designed and developed by engineers who are fully aware of all requirements in a marine environment.

Manufacturing and assembly are entirely done in-house, which ensures constant quality and a perfectly reliable product. All features and characteristics of a Craftsman Marine hatch are fully in accordance with the European Recreational Craft Directive 94/25/EC.

Enjoy your boating with Craftsman Marine products on board!

Craftsman Marine B.V.

Below you will find a survey of caution pictograms pertaining to this manual. Remarks that are related to safety bear this symbol:



**DANGER
ATTENTION**

Please adhere strictly to the recommendations in this chapter and instruct all other persons, who may be operating or servicing the hatch, to do likewise. These are the safety recommendations.

Symbols related to the text below:



Pay attention to the symbols and read the instructions in the text.



Attention
(especially with a view to a safety risk for man or material)

Table of contents

| | | |
|----------|------------------------------------|----------|
| 1 | Preface | 2 |
| 2 | Safety | 2 |
| 3 | Table of contents | 3 |
| 4 | Introduction | 4 |
| 5 | Safety precautions | 5 |
| 6 | Practical installation tips | 5 |
| 7 | Tips for safe use | 7 |
| | Opening and closing | 7 |

4 Introduction

Craftsman Marine hatches are made of special, seawater resistant aluminium profiles, hand polished to eliminate the surface pores (no collection of dirt) and thereafter anodized. This process also enhances the resistance against corrosion.

The panes are made of unbreakable acrylic of 12 mm thickness, colour: smoke grey.

The clamps are made of synthetic and other non-corrosive materials.

Craftsman Marine deck hatches, type aquila, are CE-certified, Area II a (RINA).

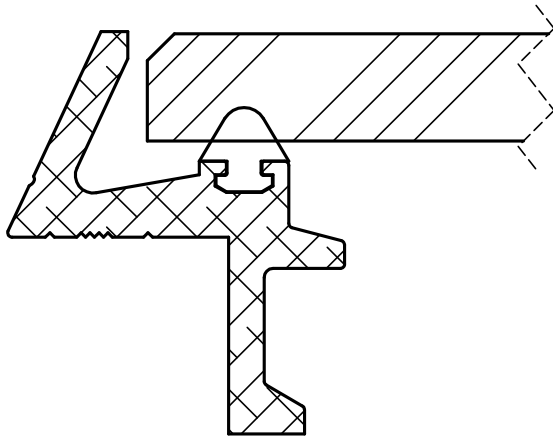

Drawing 1

5 Safety precautions



Take the required safety measures when fitting this equipment, especially while cutting into the deck: smoke, dust and glass fiber particles should be kept away by wearing goggles, a dust mask and gloves.

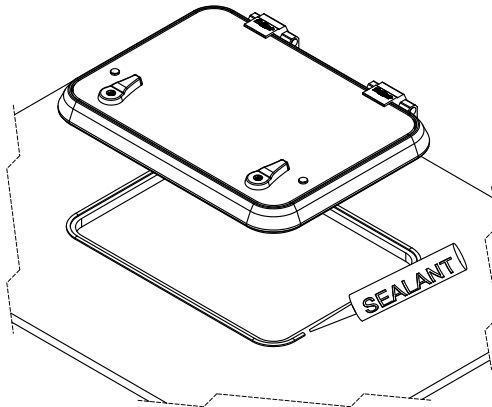

Drawing 2

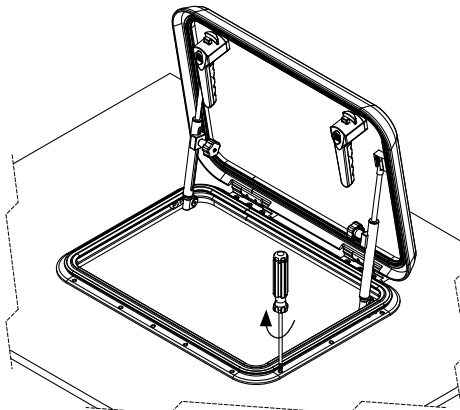

Drawing 3

Practical installation tips 6



The hatch is designed for outward opening only.



Make sure that the part of the boat (deck) into which the hatch is fitted will be absolutely flush and not curved or dented, so as to ensure proper watertightness. The maximum tolerance is +/- 1mm.



Before cutting out the hole, verify the cut-out size of the hatch. The hatch is hand-made and the dimensions may show a tolerance on the cut-out size of +/- 2mm.



Sand the cut-out section to be flush (g.r.p.), or make it free from burrs (steel).



Position the hatch into the cut-out and mark the places of the bolt holes on deck.



Take the hatch away, drill the fixation holes and remove the burrs.



Use marine grade sealant and apply it liberally onto the side of the cut-out hole (drawing 2).



Reposition the hatch, seal the bottom frame as well and tighten the hatch onto the deck by using stainless steel screws or bolts. Tightening by hand with a fitting screw driver is preferred over an electric tool, as stainless steel screws tend to break somewhat easily (drawing 3).



Use stainless steel self tapping screws 4,2 mm in diameter for polyester or stainless steel M4 bolts for a steel deck.



Do not use alkaline or acidic cleaning agents for removing any excess sealant from the deck.

6 Practical installation tips



Never use abrasive paper for cleaning the aluminium profiles. Water and a mild detergent will do just fine.



Do not use petroleum-contained cleaners for the acrylic. Also here: water and a mild detergent.



After cleaning of the aluminium profiles, apply a thin layer of transparent boat wax for additional protection.



If there is no use for it, do not tamper with the hinges; the factory setting is the right one.

Opening and closing

1. Shift the knob on the handles towards you, to unlock the handles (drawing 4).
2. Turn the handle approximately 90 degrees, as shown in the picture.
3. Push the hatch open into the chosen position.
4. The hatch can also be locked in the position shown in drawing 5, in order to get an ideal ventilation position.
5. Keep all hatches firmly closed (but not locked up) while boating!

Make sure that all handles are in the unlocked position whilst sailing!
This allows access into the boat from outside in life threatening situations (the foregoing only applies if it concerns a full-sized escape hatch.).

When the boat is left alone for a prolonged period of time, shift the knob on the handles to the lock-up position, also when the ventilation position of the escape hatch is selected. In doing so, you will minimize the risk of breaking and entering!

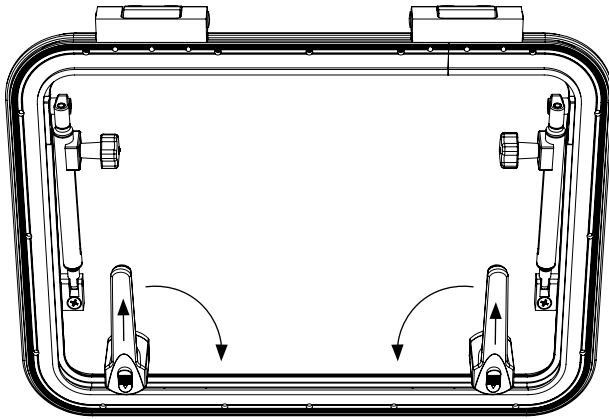

Drawing 4

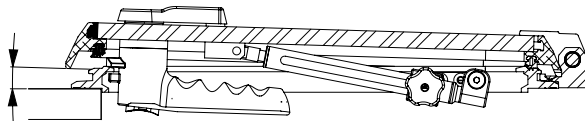

Drawing 6

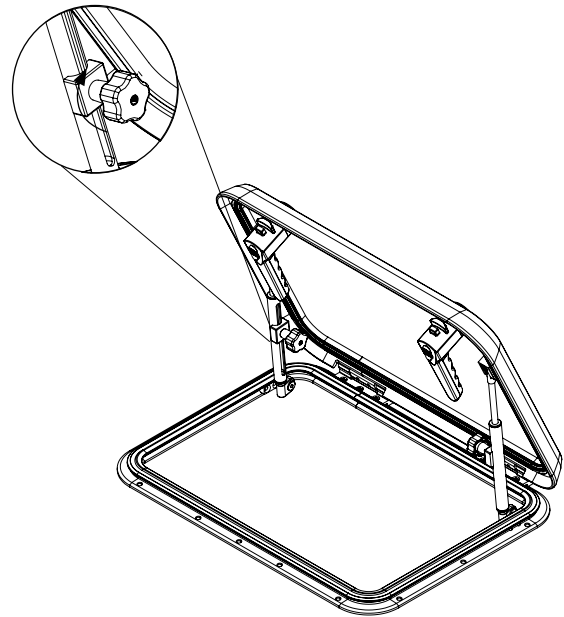

Drawing 5

info@craftsmanmarine.com
www.craftsmanmarine.com

ZD-010-009.2.1.06.10

CRAFTED WITH CRAFTSMAN MARINE