

Wall thickness Min-3mm to Max-22.5mm

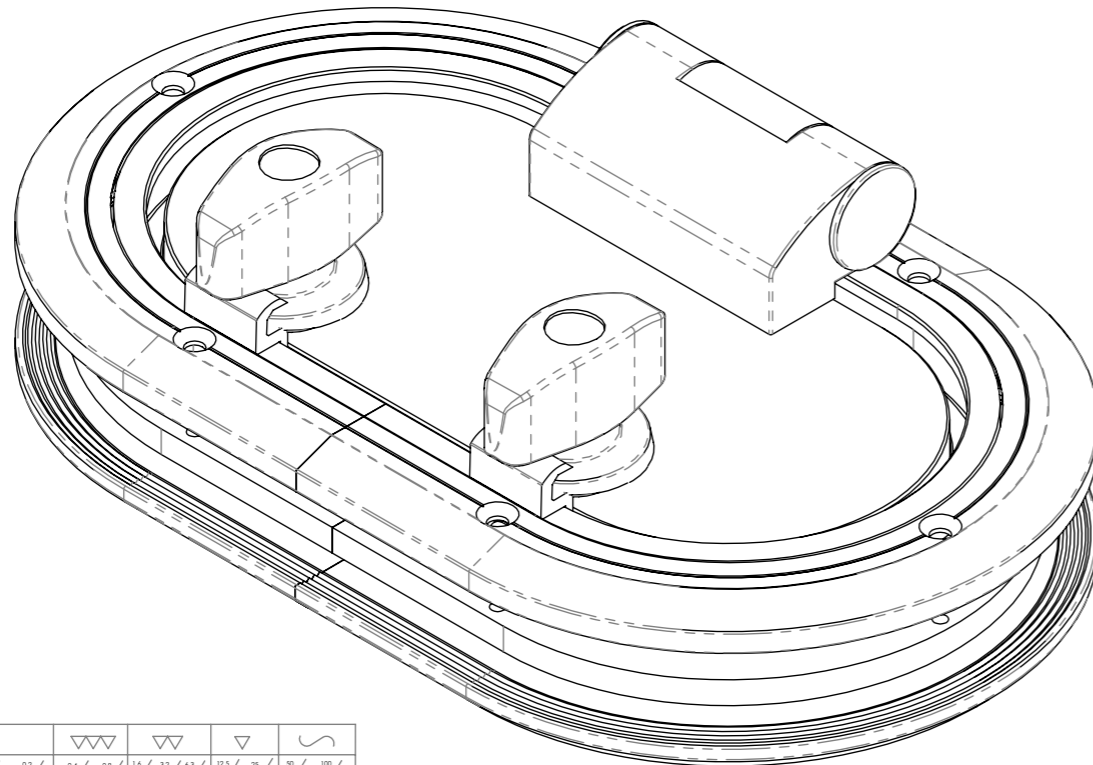

Surface Finish	▽▽▽▽	▽▽▽	▽▽	▽	~
Ra Value μm	0.012 / 0.005 / 0.005 / 0.1 / 0.2	0.4 / 0.8	1.6 / 3.2 / 6.3	12.5 / 25	50 / 100
120 to 315:±0.5	315 to 1000:±0.8	1000 to 2000:±1.2			
0 to 6 :±0.1	6 to 30 :±0.2	30 to 120 :±0.3			
General Tolerances where not specified					

Date	Revision	Description	Initials
		Main Frame Assembly 222x126	
Description			Dwg.no. FA.010.20010.01
Material:		Heat Treatment:	Weight: gms/Unit
Scale: N.T.S	Proj.:	Date: 04-08-09	
Drawn:Shankar.R	Checked:Chandru.D	Size: A3L	Dim. in: mm
Product group: CRAFTSMAN MARINE		Sheet: 1	of: 1

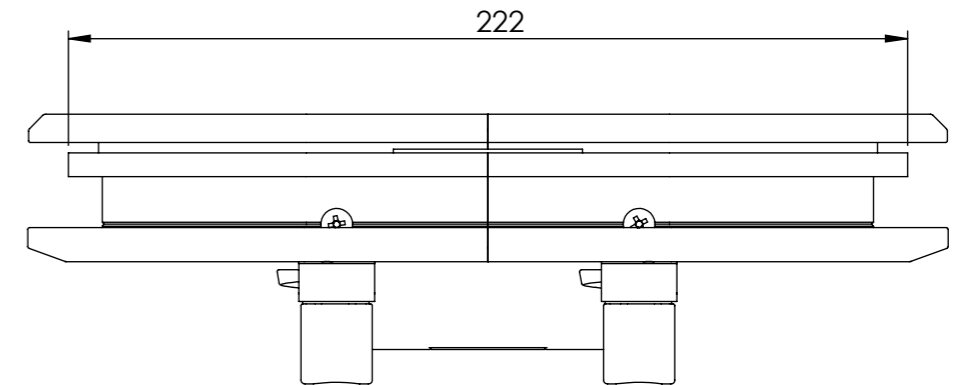
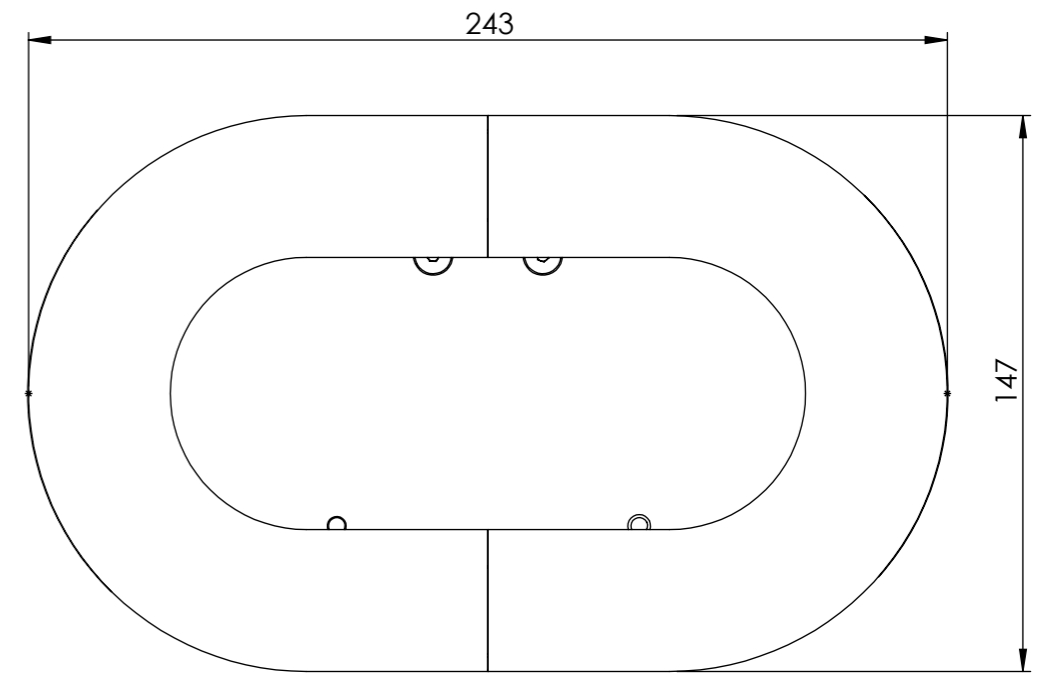
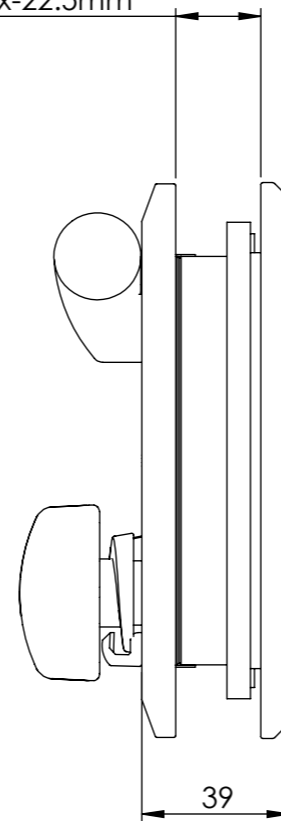
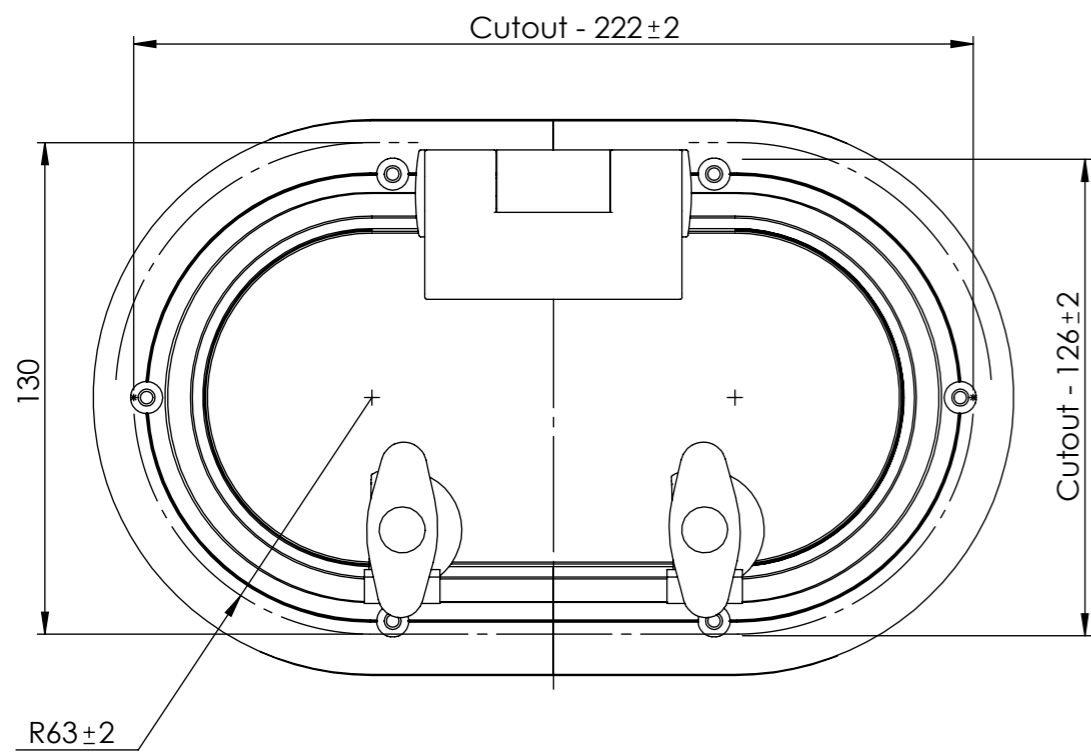

Craftsman
MARINE

Visersdijk beneden 70, 3319GV Dordrecht, The Netherlands. Tel: +31 (0)88 0062600, Fax: +31 (0)88 0062601 - info@craftsmanmarine.com - www.craftsmanmarine.com
This drawing is the property of Craftsman Marine B.V., Dordrecht. Copyright reserved acc. law. It is not to be copied (in whole or in part) or otherwise disclosed without the written consent of Craftsman Marine B.V.