

Whale® Pump Accumulator Kit

Model Number	Description
Accumulator Kits (2ltr Tanks)	
UF2214	3.0 GPM (11.5 ltrs), 12 V d.c., 2 bar (30 psi), 15mm Quick Connect Connections
UF2215	3.0 GPM (11.5 ltrs), 12 V d.c., 3 bar (45 psi), 15mm Quick Connect Connections
UF2224	3.0 GPM (11.5 ltrs), 24 V d.c., 2 bar (30 psi), 15mm Quick Connect Connections
UF2225	3.0 GPM (11.5 ltrs), 24 V d.c., 3 bar (45 psi), 15mm Quick Connect Connections

*The 'B' suffix indicates that a bulk code is available

CONTENTS

INSTALLATION AND OPERATION MANUAL

Whale® Accumulator Kit

ENG

Thank you for purchasing this Whale® product. For over 60 years, Whale® has led the way in the design and manufacture of freshwater and waste systems including: pumps, plumbing, faucets and showers for low voltage applications. The company and its products have built a reputation for quality, reliability and innovation backed up by excellent customer service.

For information on our full range of products visit www.whalepumps.com

1. LIST OF CONTENTS

1. LIST OF CONTENTS	7. WARNINGS	13. WINTERIZING
2. SPECIFICATION	8. PARTS LIST	14. SERVICE SUPPORT DETAILS
3. PRINCIPLES OF OPERATION	9. OPTIONAL EXTRAS	15. TROUBLE SHOOTING
4. TO THE USER	10. INSTALLATION	16. PATENTS AND TRADEMARKS
5. TO THE FITTER	11. INSTRUCTIONS FOR USE	17. WARRANTY STATEMENT
6. APPLICATION	12. MAINTENANCE	18. EU DECLARATION OF CONFORMITY, STANDARDS AND APPROVALS

List of Diagrams

Fig. 1 Marine Typical Installation	Fig. 3 Connecting the Strainer	Fig. 5 Wiring Diagram
Fig. 2 Pump Orientation	Fig. 4 Dual Tank System	

2. SPECIFICATION

Product Code	UF2214 (B)	UF2215 (B)	UF2224 (B)	UF2225 (B)
Pressure Pump	UF1214	UF1215	UF1224	UF1225
Accumulator Tank Size	2 ltrs (0.53 US Gals)			
Open Flow Rate (per minute)	11.5 ltrs (3.0 US Gals)			
Voltage	12 V d.c.		24 V d.c.	
Recommended Fuse Rating	10 Amp Automotive		5 Amp Automotive	
Cut Out Pressure	2 bar (30psi)	3 bar (45psi)	2 bar (30psi)	3 bar (45psi)
Weight	3.9kg (8.59lbs)			
Factory Pre-charge	1.5 bar (22 psi)	2.2 bar (32psi)	1.5 bar (22 psi)	2.2 bar (32psi)
Inlet and Outlet Size	Whale® Quick Connect 15mm Female Connections			
Materials in contact with Liquid	Glass-filled Polypropylene, Monprene®, Nitrile®, Stainless Steel, Butyl			
Minimum Wire Size	2.5mm ² (13 AWG)			
Maximum Head	20m (66ft)	30m (99ft)	20m (66ft)	30m (99ft)
Maximum Lift	3m (10ft)			

3. PRINCIPLES OF OPERATION

The Whale Accumulator Kit is designed for marine vessels for reliable and smooth consistent flow. The pump accumulator kit provides smooth flow from the system with reduced pump cycling. Please refer to the specifications (section 2) for the model range.

4. TO THE USER

Please read the following carefully before installation. **WARNING:** Please note that incorrect installation may invalidate the warranty.

5. TO THE FITTER

Check that the product is suitable for the intended application, follow these installation instructions and ensure all relevant personnel read the points listed below. Also ensure that these operating instructions are passed on to the end user.

6. APPLICATION

The Whale® Accumulator Kit is designed for installation in recreational vessels for saltwater or freshwater use, with 12 V d.c. or 24 V d.c. electrical supply only. If it is intended for use for any other purpose or with any other liquid, it is the user's responsibility to ensure that the pump is suitable for the intended use and, in particular, that the materials are fully compatible with the liquids to be used.

7. WARNINGS

1. This pump is designed for supplying water in a marine vessel. If it is intended for use for any other purpose it is the user's responsibility to ensure that the pump is suitable for the intended use.
2. **Not** suitable for pumping flammable liquids, diesel, chemicals etc. Only suitable for freshwater.
3. A Whale® strainer **must be** fitted on the inlet side of the pump to prevent any dirt/debris entering the pump
4. With all applications, it is important that a system of safe working practice is applied to installation, use and maintenance. Ensure the electric supply is turned off and water system is drained before installation. In order to securely fasten the unit, ensure that the mounting surface is a minimum thickness of 19mm (¾") when fitted.
5. **NOTE: Do not** screw directly to the hull. **Must be** mounted on a bulkhead or additional board.
6. **CAUTION:** Pump **not** intended for continuous use.
7. **WARNING:** Fire hazard. Wiring **must comply** with applicable electrical standards and include a properly sized fuse or circuit breaker. Improper wiring can cause a fire resulting in injury or death. Switch off the power while making connections. Suggested wiring information is given as guidance only. For full information, refer to the USCG, ABYC and ISO regulations for marine applications and wiring gauges, connectors and fuse protection.



8. PARTS LIST

All Whale® Accumulator Kits	Qty 1 Whale® Accumulator Kit	Qty 1 Whale® Strainer
UF2214 / UF2224 only	Qty 1 Equal Straight	Qty 1 Inline Check Valve

9. OPTIONAL EXTRAS

AK1316 Replacement Head Kit	WF1530 Whale Aquasource Clear Water Filter 15mm	
-----------------------------	---	--

10. INSTALLATION

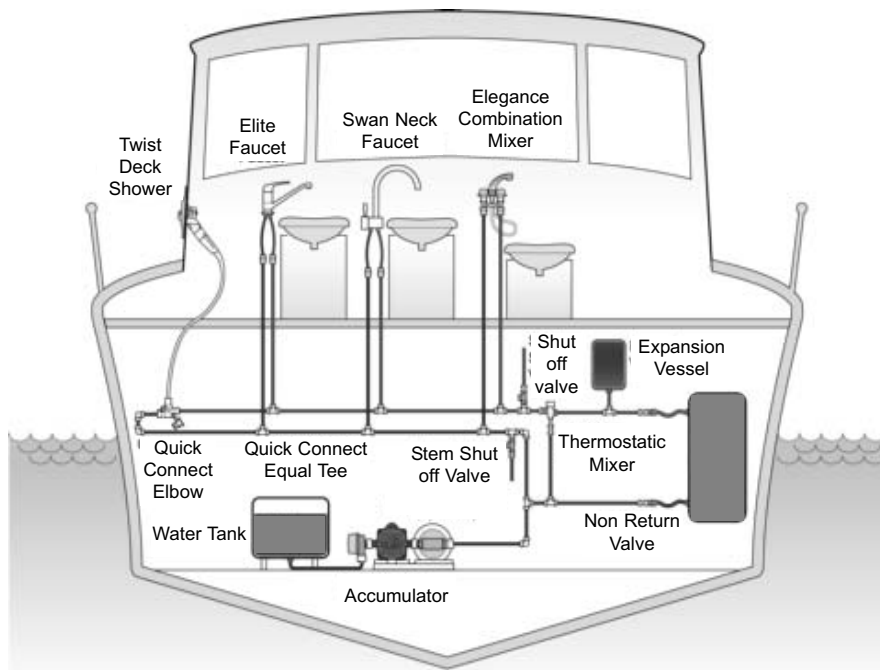

NOTE - Always disconnect power sources before installing. Incorrect installation will invalidate warranty.

The Whale® Accumulator Tank Kit is designed for use in a marine application only.

Fig. 1a Typical Installation in a Marine System
(Illustration for guidance purposes only)

10.i Mounting Instructions

- Step 1** Locate in a dry position with adequate ventilation and no more than 3m (9ft) above the water tank. In normal use, ensure the pump cannot be submerged in water.
- Step 2** Ensure the accumulator kit is mounted free of obstacles and accessible for maintenance.
- Step 3** The pump can be mounted horizontally or vertically. We recommend that the pump head is mounted below motor level (Figure 2). For advice on your specific installation, please contact Whale® support.
- Step 4** There are 4 mounting holes in the accumulator tank base. Use 4 self-tapping stainless steel screws and washers to fasten base to solid surface and support the accumulator securely (Figure 2).

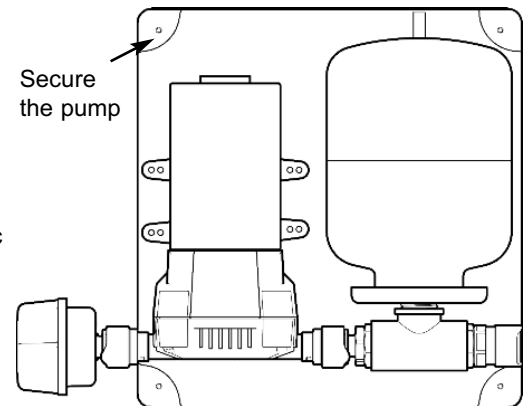

Fig 2 - Recommended Kit Mounting Orientation

10.ii Plumbing

- Check pump flow direction (as indicated on pump body) and ensure that a strainer (supplied with retail pump) is attached to the pump head inlet (Figure 3).
- Never use pipe sealant or sealing tapes on threaded adaptors, as these may enter the pump and cause failure.
- Ensure a double click into Quick Connect connections (Figure 3).

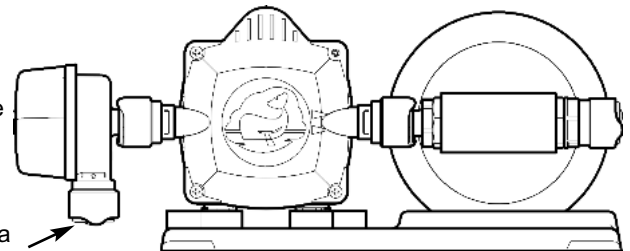
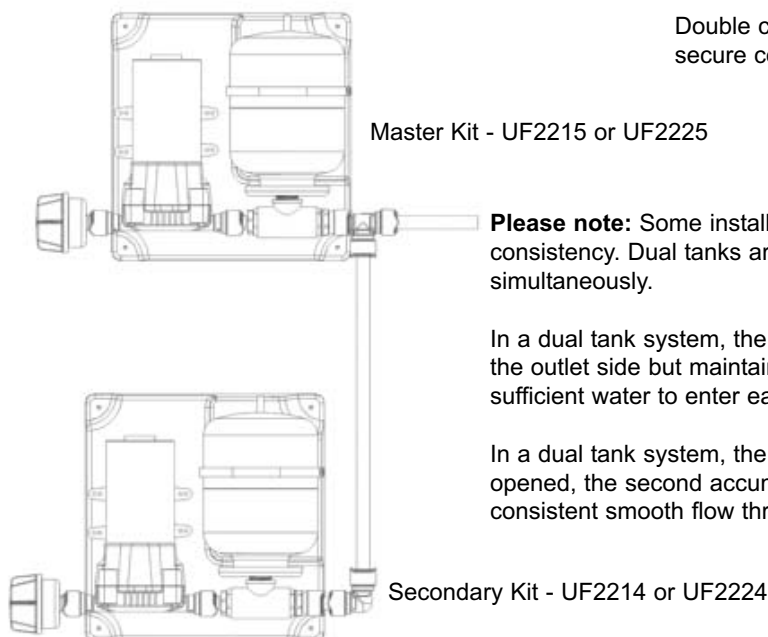

Fig 3 - Attaching The Strainer



Master Kit - UF2215 or UF2225

Secondary Kit - UF2214 or UF2224

Please note: Some installations may require a dual tank system to ensure flow consistency. Dual tanks are required in systems where there are more outlets working simultaneously.

In a dual tank system, the two accumulator kits **must be** plumbed into the same system on the outlet side but maintain inlet source through **different** plumbing - this will allow sufficient water to enter each pump.

In a dual tank system, the master tank will turn on with every use. When more outlets are opened, the second accumulator kit will begin to operate at intervals which will ensure consistent smooth flow throughout your system.

Dual System	Master Kit	Secondary Kit
12V d.c. System	UF2215	UF2214
24V d.c. System	UF2225	UF2224

Fig 4 - Dual Tank System

10.iii Electrical Wiring

WARNING: Fire hazard. Wiring **must comply** with applicable electrical standards and include a properly rated fuse or circuit breaker (Please see specification table for fuse rating - section 1).

WARNING: Improper wiring can cause a fire resulting in injury or death.

NOTE: Switch off the power prior to making connections. Suggested wiring information is given as a guide only. For full information, refer to the USCG, ABYC and ISO regulations for marine applications and wiring gauges, connectors and fuse protection.

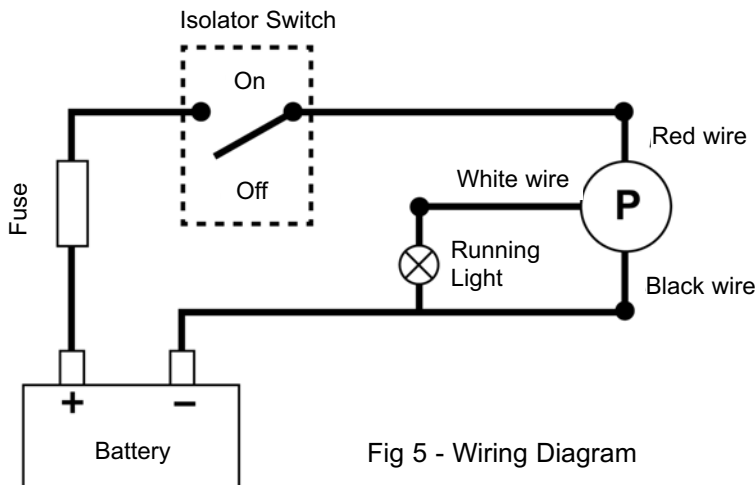

Fig 5 - Wiring Diagram

- Step 1** Use specified fuse, as indicated on motor label in the circuit.
- Step 2** Connect red wire to positive and black wire to negative.
- Step 3** The white wire can be connected to a running light to indicate when in use.
- Step 4** Fit an isolating switch with adequate current rating on the positive side of the supply.
- Step 5** To prevent the pump running continuously, turn off at isolating switch when vessel is left unattended or water supply has been allowed to empty.

11. INSTRUCTIONS FOR USE

Ensure that pump installation is thoroughly tested before first use.

Step 1 Install your pump following the advice above (see Section 10 - Installation).

Step 2 Connect the pump to the water circuit.

Step 3 Connect the power to the pump.

To ensure normal running of your water system, follow the checklist below:

- Remove air from the circuit (to prevent priming issues, drop of performance, noise and vibration).
- Check the priming of the pump (the strainer should be filled with water).
- Check the start and stop of the pump. This should be automatic by opening and closing a faucet/ shower/transom shower.

NOTE: Check your circuit regularly for any leaks or loose connections.

For any problems, please refer to the troubleshooting table, Section 15.

12. MAINTENANCE

This Whale® Accumulator Kit is designed to only require minimal maintenance.

WARNING: Ensure that the pump is disconnected from electrics and system is fully drained prior to maintenance.

For Optimal Performance

- Ensure the pump and strainer are clear of debris.
- If the pump is not operating at full capacity - disconnect electric and plumbing and check the valve arrangement inside the pump head for blockages.

Annual Checks

- Whale® advise that the vessel plumbing system is checked annually for leaks and obstructions. A pump electrics check is also advisable and the pre-charge of the tank should be verified and adjusted if required.

13. WINTERIZING

If water is allowed to freeze in the system, serious damage to the pipe work and pump may occur. Failures of this type will invalidate warranty. To best avoid this damage, completely drain the water system.

1. Drain the tank either using the pump or a drain valve.
2. Open all the faucets (including drain valve) and allow pump to purge the water from the system, and then turn the pump off.
3. Disconnect the pump and turn on to purge into an adequate basin. Only reconnect the pump when water system is to be used.
4. Remember to leave all faucets including showers open to avoid any damage except for Whale Twist™ Deck Shower.

14. SERVICE SUPPORT DETAILS

Whale (Munster Simms Engineering Ltd, 2 Enterprise Road, Bangor, N. Ireland BT19 7TA

Tel: +44 (0)28 9127 0531 Email: info@whalepumps.com

Whale Seaward Inc, 91 Manchester Valley Road, Manchester Center, VT 05255

Tel: 1 802 367 1091

Fax: 1 802 367 1095

Email: usasales@whalepumps.com

The following service kits are available for the Whale® Accumulator Kit:

AK1316 - Marine Replacement Head Kit

AK1317 - Microswitch Kit

AK1319 - Replacement Strainer

15. TROUBLE SHOOTING

Problem	Possible Cause	Potential Solution
Pump does not run	No power to pump	Check power supply. Attach leads / clean connections
	Fuse has blown	Replace fuse
	Pump is faulty	Replace pump
	Microswitch is faulty	Use the white wire to verify if the switch is faulty and replace if necessary (AK1317).
Pump runs but no water appears	No water getting to pump / Blockage in pipework	Check the water tank is not empty. Check strainer is not blocked. Check all connections from tank to inlet of pump are secure - any air leaks will prevent prime
	Pressure relief valve too low	Check water supply level and pressure relief settings are appropriate for the system
	Water leaking at outlet side of pump	Check pipework/fittings for leaks and repair. Check system drain plugs are closed
Pump runs but will not switch off	Water leaking at outlet side of pump	Check pipework/fittings for leaks and repair. Check system drain plugs are closed
	Insufficient water getting to pump	Check water supply levels
Pump cycles on and off periodically when all the taps are closed.	Water leaking at outlet side of pump	Check pipework/fittings for leaks and repair. Check system drain plugs are closed. System pressure relief valve too low (usually located at heater / calorifier)
Noisy operation	Pump drawing air	See 'no water getting to pump' (above)
	Noise created by vibration	Check pump is secured to solid surface. Check pump body is not in contact with hard surfaces. Locate away from interfering surfaces. Check pipework is securely supported
Pump cycles on and off excessively when outlets are open	Excessive back pressure between pump and accumulator tank.	Check connections for any blockage and repair.
	Incorrect tank pre-charge pressure.	Turn power off to release pressure in the system. Check precharge level is at recommended level (see section 2)
Low flow	Bore of pipework connection too small	Ensure 10mm minimum bore.
	Power supply to pump	Check power supply to pump uses correct wire gauge, in line with relevant standards, to give full voltage at pump. Check battery is not discharged
	Pipework/connections crushed due to over tightened jubilee clips	Replace damaged connections
	Pump too far from water tank	Pump is best situated beside water tank
	Water leaking at outlet side of pump	Check pipework/fittings for leaks and repair Check system drain plugs are closed
	Pump strainer clogged	Remove clear lid, rinse and replace to main strainer body (retain strainer mesh on lid)

16. PATENTS AND TRADEMARKS

Whale® is a registered trademark of Munster Simms Engineering Limited trading as Whale and Whale Seaward Inc.

17. WARRANTY STATEMENT

This Whale® product is covered by 2 years warranty. Please see enclosed document for details of our Statement Of Limited Warranty.

18. EU DECLARATION OF CONFORMITY, STANDARDS & APPROVALS

We hereby declare, under our sole responsibility, that the enclosed equipment complies with the provisions of the following EC Directives.

Electromagnetic Compatibility Directive 2004/108/EC on the approximation of the laws of the Member States relating to electromagnetic compatibility.

CE mark affixed: March 2014

Basis on which conformity is declared - The above equipment complies with the protection requirements of the EMC Directive.

Standards applied

ISO10133:2000	Extra-low voltage DC Installation
EN55014-1:2006	EMC Emissions
EN55014-2:1997+A2:2008	EMC Immunity
EN28846 :1993	Ignition Protection
ABYC-H23	Installation of Potable Water

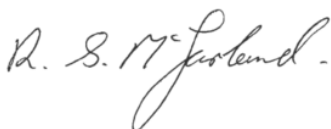

Date: March 2014
Position: Engineering Director



©Copyright Whale 2014- All rights reserved.

WHALE®, is a registered trademark of Munster Simms Engineering Limited, Bangor Northern Ireland trading as Whale (and Whale Seaward Inc).

Whale's policy is one of continuous improvement and we reserve the right to change specifications without prior notice. Illustrations are for guidance purposes only.

ref: sh_181.257_v1_0214

Munster Simms Engineering Ltd

2 Enterprise Road, Bangor, Co. Down, Northern Ireland, BT19 7TA

Tel: +44 (0)28 9127 0531

Email: info@whalepumps.com

Web: www.whalepumps.com

Whale Seaward Inc

91 Manchester Valley Road, Manchester Centre, VT 05255

Tel: +1 802-367-1091

Email: usales@whalepumps.com

Web: www.whalepumps.com