

HARKEN®

USA – Tel: (+1) 262-691-3320 • Web: www.harken.com • Email: harken@harken.com
 Italy – Tel: (+39) 031.3523511 • Web: www.harken.it • Email: techservice@harken.it

ONLINE INSTRUCTIONS

22 mm, 27 mm, 32 mm CB Genoa Lead Cars

G222B, G224B G272B, G273B, G273B.HL, G274B, G274B.HL, G323B, G324B



Strictly follow all instructions to avoid an accident, damage to your vessel, personal injury or death. See www.harken.com for additional safety information.

IMPORTANT: See Inspection and Maintenance at end of manual.

Features

Sheaves feature high-load axle bearings for easy trimming.

Captive ball bearings: make cars easy to load and maintain.

Free running ball bearings in car and in genoa sheave: make it easy to adjust car under load.

Sheave carrier pivots to adapt to lead angles.

One piece car body: machined from 6061-T6 aluminum for strength and durability.

Hardcoat anodized: Hard Lube impregnated for durability

Specifications

Part No.	Fits CB Track	End Control	Purchase	Maximum working load		Breaking load	
22 mm Small Boat							
G222B	2720/373	2740	2:1	1250	567	2500	1134
G224B	2720/373	2742	4:1	1250	567	2500	1134
27 mm Midrange							
G272B	R27/1602	E2730	2:1	2300	1043	5000	2268
G273B	R27/1602	E2750	3:1	2300	1043	5000	2268
G273B.HL	R27/1602	E2750	3:1	3600	1632	7200	3266
G274B	R27/1602	E2750	4:1	2300	1043	5000	2268
G274B.HL	R27/1602	E2750	4:1	3600	1632	7200	3266
32 mm Big Boat							
G323B	R32/3159	E3250.HL/3174	3:1	5000	2268	10000	4536
G324B	R32/3159	E3250.HL/3174	4:1	5000	2268	10000	4536

Important: CB cars only roll on CB track.

Cars listed above are CB style and only roll on CB track. Older tracks do not have the grooves at the waist for the retaining clips. If cars do not fit you must replace track. Contact Harken.

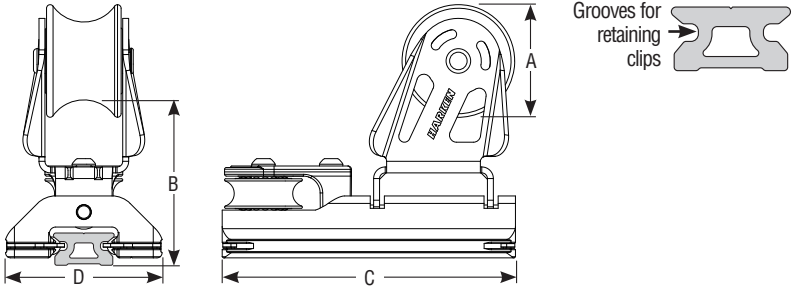

Part No.	A		B		C		D	
	in	mm	in	mm	in	mm	in	mm
22 mm Small Boat								
G222B, G224B	1½	38	2⅝	67	4⅛	105	2¼	57
27 mm Midrange								
G272B, G273B	2¼	57	2⅞	73	5⅜	132	2¾	70
G273B.HL	2¼	57	2¾	70	9	229	2¾	70
G274B	2¼	57	2⅞	73	5⅜	132	2¾	70
G274B.HL	2¼	57	2¾	70	9	229	2¾	70
32 mm Big Boat								
G323B, G324B	3	76	3½	88	9⅞	231	3⅞	85

Terms

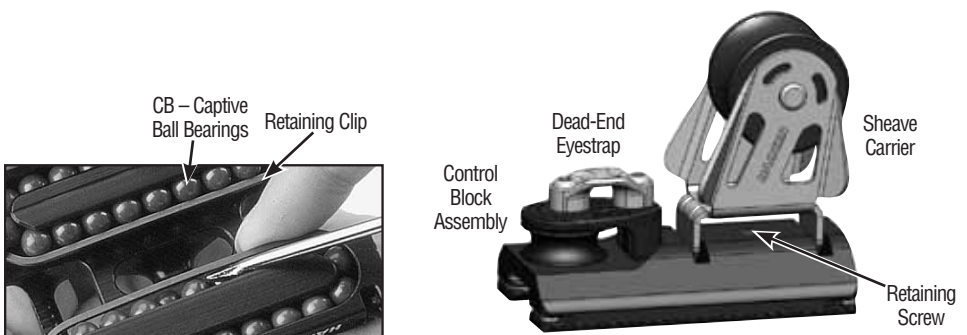

Attaching Splice to Deadend on Car or Controls

- 1) Loosen one dead-end eyestrapscrew on end control. Remove other screw and rotate bail to capture splice loop. Install screws using a threadlocker such as blue Loctite® on screws.
- 2) When using smaller control line pass eye through dead-end eyestraps and run tail through to make a hitch without undoing screws.



Installing Traveler Car on Track

Install forward end control. Position car at end of track with control block assembly facing towards the bow. Gently roll car onto track. Car should roll on easily, if not check to make sure you are using CB track. **Do not remove ball retaining wires.** Cars will not roll unless they have retaining clips. If any balls are lost refer to following instructions for quantities and how to load. Attach shock cord to aft leg of sheave carrier.

Reeving Lead Car and Control Blocks

Install end stop. Install control line turning block and cleat. See chart below. Install shock cord retrieval system.

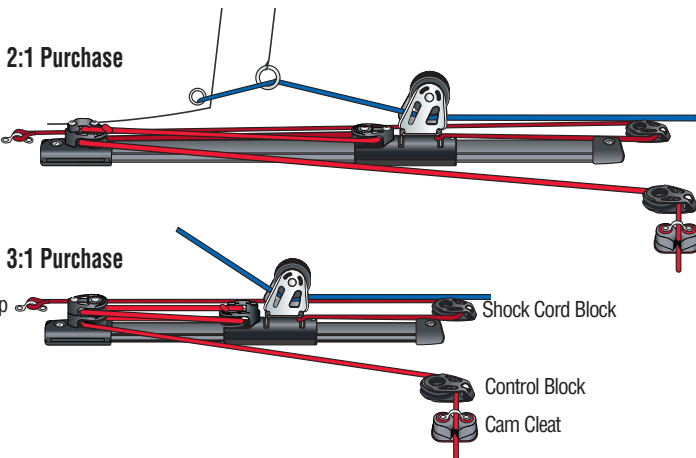

Deck-Mounted Control Line Parts

Part No.	Size	Control Block	Cam-Matic® Cam Cleat	Shock Cord Block/eyestraps
G222B, G224B	Small Boat	350/2644	365/150	233/073
G272B, G273B, G274B	Midrange	2644/2606	150	233/073
G273B.HL, G274B.HL	Midrange HL	2606/6106	150	350/073
G323B, G324B	Big Boat	2606/6106	150/280	350/073

Loading Ball Bearings into CB Cars

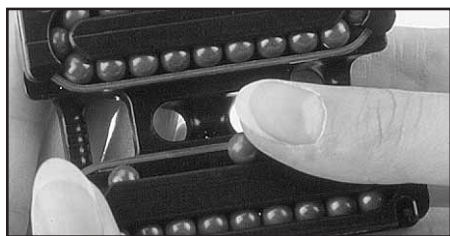

Position car on edge with retaining clip in place. Gently push one ball at a time into car from center of clip. Allow balls to roll into return race and insert remaining balls. **Do not overfill car!**

Ball Replacement Chart

Car	Car Length		Balls Per		Order	Balls Per Set	Ball Ø	
	in	mm	Car	Balls			in	mm
G222B, G224B	4 1/8	105	60	Torlon®	177	21	1/4	6
G272B, G273B, G274B	5 3/16	132	60	Torlon®	1526	25	5/16	8
G273B.HL, G274B.HL	9	229	96	Torlon®	1526	25	5/16	8
G323B, G324B	9 1/8	231	90	Torlon®	547	25	3/8	10

Removing Ball Bearings from CB Cars

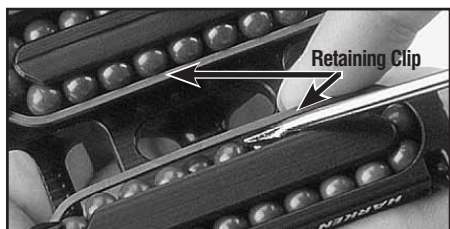

Position car on edge and gently push one ball at a time from center of retaining clip. **Do not remove retaining clip from car!**

Adding Pivot Stop—Sold Separately

A pivot stop will keep sheave carrier from hitting side of cabin.

Car Part No.	Pivot Stop Part No.
G222B, G224B	H-36086A
G272B, G273B, G274B	H-54398
G273B.HL, G274B.HL	H-54999
G323B, G324B	H-54399

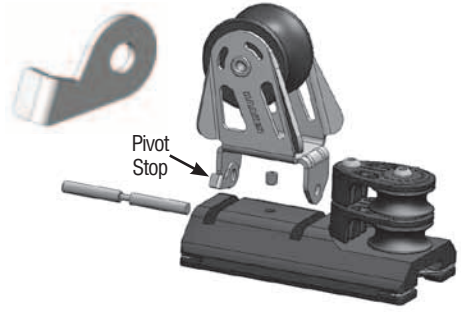

Mounting Pivot Stop

If possible, remove car from track.

1. Remove retaining screw. Screw may be located under sheave carrier. Angle sheave to access.
2. Angle car and carefully tap on end to get pivot post to come out.
3. Pull out pivot post and remove sheave carrier.
4. For port side hold pivot stop near aft leg of sheave carrier as shown above and insert into car. Push pivot post into hole in end of car until it stops. Screw plastic retaining screw into car to hold pivot post in place.
5. For starboard side, mount stop aft of leg as shown.

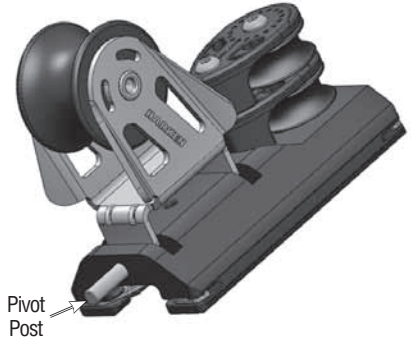
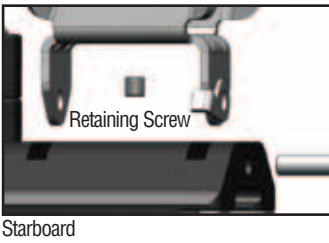
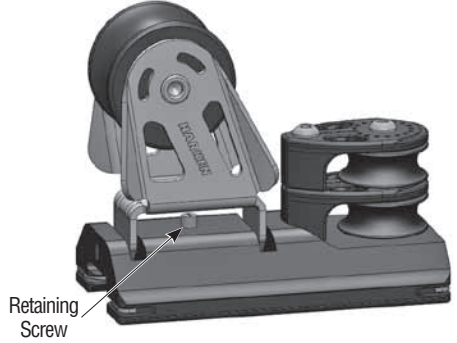

For G27 High-Load Cars and G32 cars locate pivot stop on front leg. Be sure to capture bushing located under aft leg when inserting pivot post.

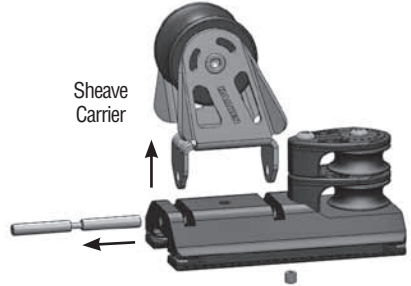
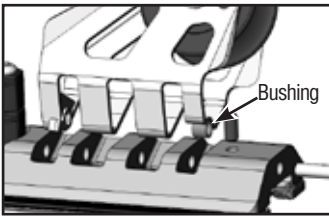

Loctite® is a trademark of Henkel AG & Company KGaA
 McLube™ is a registered trademark of McGee Industries, Inc.
 Torlon® is a registered trademark of Solvay Advanced Polymers.

Inspect

Frequently inspect retaining screw and control block fittings for signs of loosening and replace as necessary. Make sure every installation includes Harken track end stops. Arrange control tackle so cars do not hit end stops under load.

Maintenance

Traveler Cars: Clean by frequently flushing with fresh water. Periodically clean car by squirting a detergent/water solution into center openings. Roll car back and forth to distribute evenly then flush bearings with fresh water.

Do not use spray lubricants because ball bearings may skid not roll. Apply one to two drops of McLube® OneDrop™ to ball contact surfaces of track. Roll car back and forth through OneDrop™ several times to distribute onto bearings. Wipe remaining OneDrop™ off track. OneDrop™ is preferred but you can also use one to two drops of a light machine oil, such as 3-in-1. Too much oil attracts dirt.

Track: Clean with detergent and water.

Important: Exposure to some teak cleaners and other caustic solutions can result in discoloration of part and is not covered under the Harken warranty.



Warranty

For additional safety, maintenance and warranty information see www.harken.com/manuals or the Harken® catalog. Printed in USA

4352/12-20-12